



HYBRID WATER HEATER

User Manual



Model
VH-199

Keep this manual near the water heater for future reference whenever maintenance or service is required.



Certified to
NSF/ANSI 5 & 372



* Lead Free

WARNING: If the information in these instructions is not followed exactly, a fire or explosion may result causing property damage, personal injury or death.

- Do not store or use gasoline or other flammable vapors and liquids in the vicinity of this or any other appliance.
 - WHAT TO DO IF YOU SMELL GAS
 - Do not try to light any appliance.
 - Do not touch any electrical switch; do not use any phone in your building.
 - Immediately call your gas supplier from a neighbor's phone. Follow the gas supplier's instructions.
 - If you cannot reach your gas supplier, call the fire department.
 - Installation and service must be performed by a qualified installer, service agency or the gas supplier.
- The installation must conform with local codes or, in the absence of local codes, the National Fuel Gas Code, ANSI Z223.1/NFPA 54 and/or CSA B149.1, Natural Gas and Propane Installation Code.
 - When applicable, the installation must conform with the Manufactured Home Construction and Safety Standard, Title 24 CFR, Part 3280 and/or CAN/CSA Z240 MH Series, Mobile Homes.

Safety Information

The following safety symbols are used in this manual for user's safety. Read this manual carefully and follow all instructions to avoid property damage, fire, explosion, personal injury, or death.

 **Danger** Indicates an imminently hazardous situation which, if not avoided, will result in severe injury or death.

 **Warning** Indicates a potentially hazardous situation which, if not avoided, will result in injury or death.

 **Caution** Indicates a potentially hazardous situation which, if not avoided, could result in property damage.

 **Danger**

If you smell gas:

- Do not try to light any appliance.
- Do not touch any electrical switches or use landline phones.
- From a neighbor's phone, call your gas provider and follow their instructions.
- If you cannot reach your gas provider, call the fire department.

Do not use or store flammable products, such as gasoline, solvents, or adhesives in the same room or area as the water heater.

- Vapors from flammable liquids can explode and/or catch fire causing death or severe burns.
- Keep flammable products far away from the water heater and store them in approved containers. Keep the containers tightly closed and out of the reach of children.
- The Water heater has a main burner flame that can come on at any time and will ignite flammable vapors.
- Vapors cannot be seen and are heavier than air. Vapors travel a long way on the floor and can be carried from other rooms to the main burner flame by air currents.

Avoid using hot water over 125°F.

- Water temperature over 125°F can cause severe burns or death from scalding.
- Children, the disabled and the elderly are at highest risk of being scalding.
- Test water before bathing or showering.

Temperature	Time to Produce Serious Burn	Temperature	Time to Produce Serious Burn
120 °F (48 °C)	More than 5 minutes	140 °F (60 °C)	Less than 5 seconds
125 °F (51 °C)	1.5 to 2 minutes	145 °F (62 °C)	Less than 3 seconds
130 °F (54 °C)	Approx. 30 seconds	150 °F (65 °C)	Approx. 1.5 seconds
135 °F (57 °C)	Approx. 10 seconds	155 °F (68 °C)	Approx. 1 second



Warning

- **Do not store combustibles, such as papers or laundry, near the water heater or venting system.**
Failure to do so may result in fire or explosion.
- **Do not store or use gasoline or other flammable liquids near this water heater.**
Failure to do so may result in fire or explosion.
- **Do not store or use compressed gases, such as hair sprays or spray paints, near the water heater or venting system, including the vent termination.**
Failure to do so may result in fire or explosion.
- **Do not remove the front cover unless the power to the water heater is turned off or disconnected.**
Failure to do so may result in electric shock.
- **Do not touch the internal components of the water heater or the power cord with wet hands.**
Failure to do so may result in electric shock.
- **Do not operate the water heater with the front cover opened.**
Failure to do so may result in fire or carbon monoxide (CO) poisoning, which may result in property damage, personal injury, or death.
- **Do not operate the water heater without proper venting.**
Failure to do so may result in fire or carbon monoxide (CO) poisoning, which may result in property damage, personal injury, or death.
- **Shut off the gas supply if the water heater is damaged.**
Have your installer or plumber show you the location of the gas shut off valve and demonstrate how to close the valve. If the water heater is damaged as a result of overheating, fire, flood, or any other reason, close the manual shut off valve and do not operate the water heater again until it has been inspected by a qualified technician.
- **Should overheating occur or if the gas supply fails to shut off, turn off the manual gas shut off valve.**



Caution

- **Do not use the water heater for anything other than its intended purpose, as described in this manual.**
Failure to do so may result in property damage, personal injury, or death.
- **Do not turn on the water heater unless the water and gas supplies are fully opened.**
Failure to do so may damage the water heater.
- **Do not use unapproved replacement or accessory parts.**
Failure to do so may result in improper or dangerous operation and will void the manufacturer's warranty.
- **Label all wires prior to disconnection when servicing controls.**
Wiring errors can cause improper and dangerous operation. Verify proper operation after servicing.
- **Do not place anything in or around the vent terminals that could obstruct the air flow in or out of the water heater.**
Failure to do so may result in fire or carbon monoxide (CO) poisoning, which may result in property damage, personal injury, or death.
- **Do not attempt to repair or replace any part of the water heater, unless it is specifically recommended in this manual.**
For all other service, contact an authorized technician or licensed professional. Improper adjustments, alterations, service, or maintenance may lead to property damage, personal injury, or death and will void your warranty.
- **Do not operate the water heater if you suspect something might be wrong with it.**
Doing so may result in product damage or personal injury.
- **Do not allow children to operate or have access to the water heater.**
Doing so may result in product damage or personal injury.
- **Do not turn on the water heater unless the water and gas supplies are fully opened.**
Doing so may damage the water heater.
- **Do not use this appliance if any part has been immersed in water.**
Immediately call a qualified service technician to inspect the appliance and replace any part of the control system and/or any gas control which has been immersed in water.
- **This water heater has been approved for use in the USA and Canada only.**
Using the water heater in any other country will void the manufacturer's warranty.

Table of Contents

Safety Information 2

Front Panel 5

 Digital Display and Icons 5

 Buttons 5

Operating the Water Heater 6

 Turning the Water Heater On or Off 6

 Setting the Water Temperature 6

 Viewing Basic Information 6

Maintaining the Water Heater 8

 Draining the Water Heater 8

 Cleaning the Inlet Nipple Filter 9

 Cleaning the Air Intake Filter 9

 Flushing the Heat Exchanger 10

 Protecting the Water Heater from Freezing 11

 Maintenance Schedules 11

Troubleshooting 12

 Basic Problems 12

 Error Codes 13

LIMITED WARRANTY for VST Products 14

Front Panel



After installing the water heater, you must proceed to Calibration Mode before using the water heater.

Digital Display and Icons

The digital display and icons on the front panel provide important information required for the operation of the water heater. Refer to the table below for detailed information.

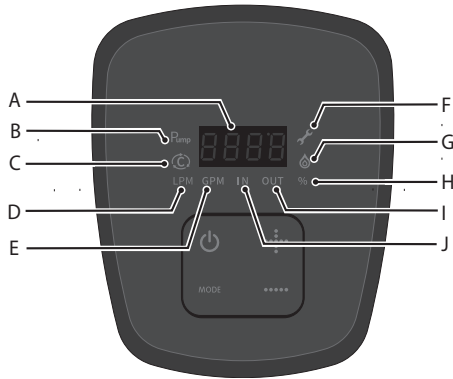

	Icon	Description
A		Digital display Displays water temperature, error codes, etc.
B		Pump Indicates recirculation pump operation.
C		Cascade Indicates cascade operation.
D	LPM	Liter Per Minute Indicates flow rate of hot water supply in LPM.
E	GPM	Gallon Per Minute Indicates flow rate of hot water supply in GPM.
F		Error Indicates error.
G		Combustion Indicates gas burner operation.
H	%	Combustion load Indicates combustion load in percentage.
I	OUT	Out temperature Indicates temperature of hot water supply.
J	IN	In temperature Indicates temperature of cold water inlet.

Buttons

Using the buttons on the front panel, you can turn the water heater on or off, adjust the water temperature, and change modes to monitor the operation status. Refer to the table below for detailed information.



	Button	Description
A		Power Turns the water heater on or off.
B	MODE	Mode Changes the mode.
C		UP Increases the temperature.
D		Down Decreases the temperature.

Operating the Water Heater

Turning the Water Heater On or Off

To turn the water heater on or off, press the  button.

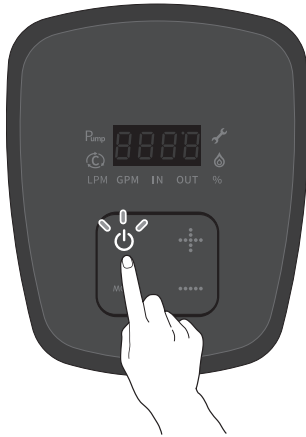

When the water heater is on, the water temperature which has been set recently will appear on the digital display.

Setting the Water Temperature





Danger

If your household includes children, or elderly or disabled individuals, consider using a lower temperature setting.



Caution

Test the temperature of the water before use.

To set the water temperature, press the  (Up) or  (Down) buttons until the desired temperature appears on the digital display.

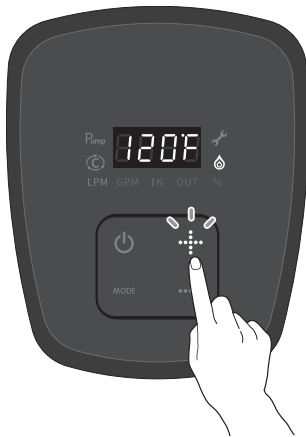

Temperature range

°F	98	100	102	104	106	108	110	112	114
°C	37	38	39	40	41	42	43	44	45
°F	116	118	120	125	130	135	140	150	160
°C	47	48	50	52	54	57	60	65	70



Notice

- Between 98°F (37°C) to 120°F (50°C), the temperature can be set in 2°F increments.
- Between 120°F (50°C) to 140°F (60°C), the temperature can be set in 5°F increments.
- Between 140°F (60°C) to 160°F (70°C), the temperature can be set in 10°F increments.
- Between 120°F (50°C) to 125°F (52°C), to change the temperature, hold down the  button for 5 sec to unlock.
- When hot water is in use, the temperature can be set with +/- 10°F from the current water temperature to prevent users from being scalded. For example, if the water temperature is 120°F (50°C), the temperature can be set between 110°F (43°C) to 130°F (54°C).

Viewing Basic Information

To view information about the water heater, press the **MODE** button.



Notice

By pressing the MODE button repeatedly, different information will be viewed in the digital display.

● LPM (Liter Per Minute)

Indicates flow rate of hot water supply in LPM.



● OUT (Out temperature)

Indicates temperature of hot water supply.



● GPM (Gallon Per Minute)

Indicates flow rate of hot water supply in GPM.



● % (Combustion load)

Indicates combustion load in percentage.



● IN (In temperature)

Indicates temperature of cold water inlet.



Maintaining the Water Heater



Before cleaning the water heater, make sure the water heater is turned off and the power supply is disconnected. The water heater may remain hot for few minutes after it is turned off. Wait until the water heater has cooled down before cleaning to prevent burns.

Draining the Water Heater

To perform maintenance tasks or to prevent the water heater from freezing when it will not be used for an extended period, the water heater must be drained.

To drain the water heater:

- 1 Press the  button to turn off the water heater.
- 2 Disconnect the power supply to the water heater.
- 3 Turn off the gas valve.

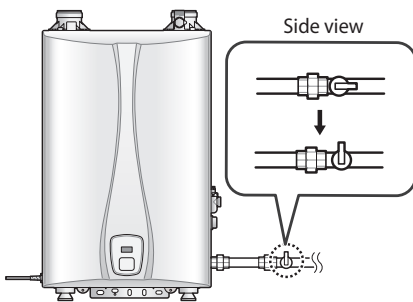

- 4 Turn off the water supply valve on the inlet to the water heater.

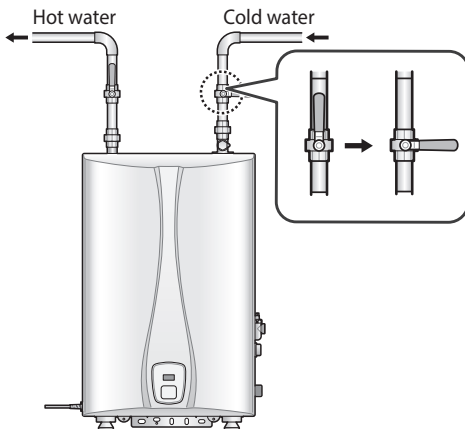

Notice

If there is no water supply valve, turn off the water supply at the water main.

- 5 Open all hot water faucets and drain the water remaining in the plumbing lines.
- 6 Place a bucket under the drain valve.
- 7 Open the drain valve and allow any residual water to drain from the water heater.

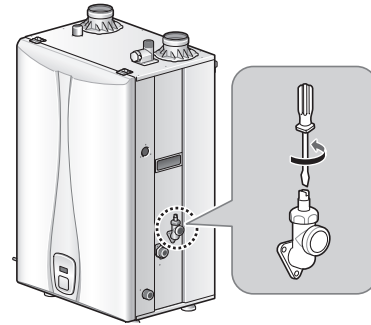

- 8 Close the drain valve when the water is completely drained.

Notice

Follow the steps in reverse order to refill the water heater.

■ Cleaning the Inlet Nipple Filter

To clean the inlet nipple filter:

- 1 Drain the water heater. Refer to "Draining the Water Heater" on page 8.
- 2 Remove the inlet nipple filter from the top of the water heater.

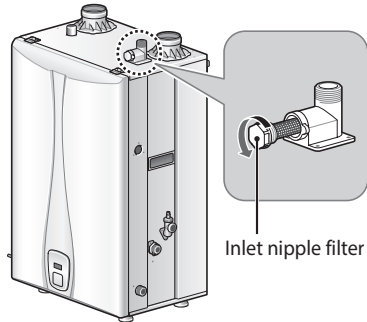

- 3 Rinse the inlet nipple filter with clean running water.
- 4 Reinsert the inlet nipple filter.
- 5 Refill the water heater. Refer to "Draining the Water Heater" on page 8.

■ Cleaning the Air Intake Filter

To maintain the water heater properly, clean the air intake filter every 2–3 months. If the air intake filter is clogged by dust or lint, the water heater will cease to operate or error can occur.

To clean the air intake filter:

- 1 Press the  button to turn off the water heater.
- 2 Disconnect the power supply to the water heater.
- 3 Remove the water heater front cover by loosening the 2 Phillips screws securing it to the case.

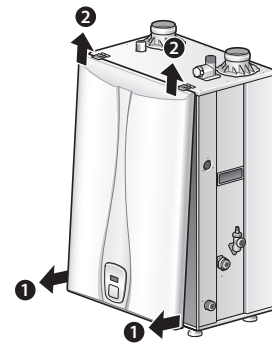
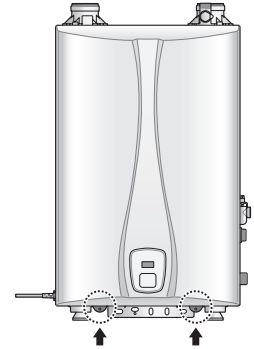

- 4 Remove the air intake filter located under the air intake connector.

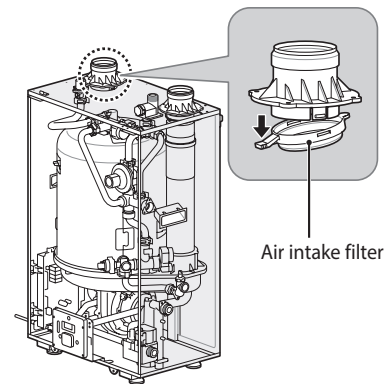

- 5 Rinse the air intake filter with clean running water.
- 6 Dry the air intake filter completely.
- 7 Reinsert the air intake filter.
- 8 Replace the front cover.

Flushing the Heat Exchanger

Notice

Flushing the Heat Exchanger annually is a required maintenance. In hard water conditions, it needs to take a place more often.





Flushing the Heat Exchanger is a somewhat complicated procedure. Read the following instruction carefully before attempting this procedure.

Before Flushing the Heat Exchanger, gather the following items.

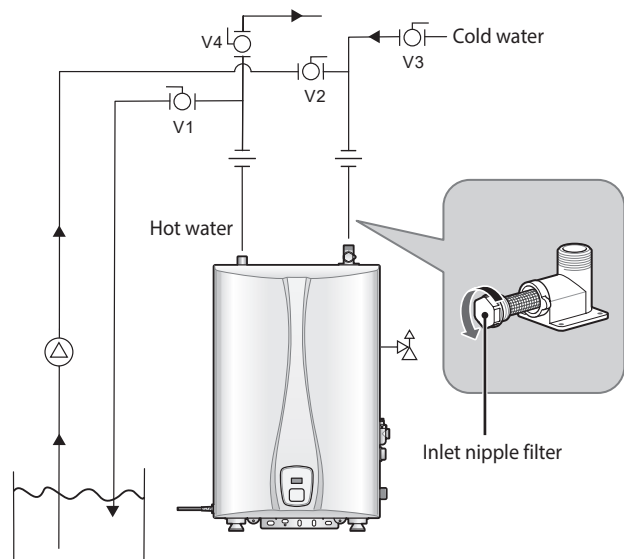
- A bucket that is 5 gallons or larger
(The capacity of this water heater is 3 gallons.)
- Cleaning solution diluted with water
- 3 hoses
- A water circulation pump

- 1 Disconnect electrical power to the water heater.
- 2 Close the shutoff valves on both the cold water and hot water lines (V3 and V4).
- 3 Connect one of hoses to the circulation pump outlet and the cold water line at the (V2) valve.
- 4 Connect one hose to the circulation pump inlet and place the free end in the bucket.
- 5 Connect the other hose to the hot water line at the (V1) valve and place the free end in the bucket.
- 6 Pour approximately 4 gallons of cleaning solution diluted with water into the bucket.
- 7 Open both valve(V1 and V2) on the hot water and cold water lines.
- 8 Operate the pump and allow the solution to circulate through the water heater for at least 1 hour.
- 9 Turn off the pump and clean the inlet nipple filter:
 - a. Remove the inlet nipple filter from the top of the water heater. Refer to the illustration to the side.
 - b. Rinse the inlet nipple filter with clean running water.
 - c. Reinsert the inlet nipple filter.



- | | |
|--|---|
|  Ball valve |  Circulation pump |
|  Union |  Pressure relief valve |

- 10 Rinse the cleaning solution from the water heater:
 - a. Remove the free end of the drain hose from the bucket. Place in sink or outside to drain.
 - b. Close the valve(V2) and open shutoff valve(V3). Do not open shutoff valve(V4).
 - c. Allow water to flow through the water heater for at least 10 minutes.
 - d. Close the valve(V1) and open shutoff valve(V4).
- 11 Disconnect all hose.
- 12 Restore electrical power to the water heater.

■ Protecting the Water Heater from Freezing



- To protect the water heater from freezing, recommend the use of a direct vent exhaust and intake system. Ensure that the exhaust vent pipe and the air intake pipe are both connected directly from the collars on the top of the water heater to the outdoors. This type of vent system minimizes air movement within the water heater.
- Freezing damage usually occurs due to back-drafting caused by negative pressure in the building. This is not a manufacturing defect, and therefore, VST will not warrant any damage due to freezing. The installer is responsible for ensuring that there is sufficient make-up air to avoid such a situation, and the owner is responsible for ensuring protection against freezing.

To protect the water heater from freezing, follow these guidelines:

- If the water heater will not be used for an extended period of time, drain the water heater.
- Do not unplug the power supply cord, except for routine maintenance. The water heater has a freeze protection function that warms up the water heater when the temperature inside the water heater becomes lower than 43°F (6°C). The freeze protection function will operate regardless of whether or not the front panel is turned on or off, as long as the power supply is still connected.
- If the power or gas supply must be disconnected for an extended period, drain the water heater.
- Protect and insulate all water pipes, including the condensate trap drain line, from freezing.

Notice

If you suspect that the water heater is frozen, contact an authorized technician or licensed professional.

■ Maintenance Schedules



A qualified technician should inspect the water heater at the beginning of every heating season and/or when there is a problem.

● Owner maintenance

Daily

- Check that the area where the water heater is installed is free of combustible/flammable material and air-contaminants.
- Visually inspect the exterior of the water heater.

Monthly

- Inspect the condensate trap and the PVC fittings.
- Visually inspect the piping (water and gas) for leaks.
- Visually inspect the vent piping for signs of leakage and blockage.

Every 6 months

- Inspect the piping (water and gas) for leaks.
- Inspect the vent piping for leakage and blockage.
- Test to make sure the pressure relief valve is operating properly.
- Be carefully to avoid contact with hot water coming out of the pressure relief valve and to prevent water damage when you operate the relief valve.

● Service technician maintenance

Periodically

- Inspect the interior of the water heater.
- Clean the condensate trap and fill with fresh water.
- Clean the air intake filter.
- Check for leaks (gas, water, flue, and condensate).
- Check the system pressure (gas, and water).
- Check ignition and flame rod.
- Check wiring connections.

Troubleshooting

Basic Problems

If there is a problem with the water heater, refer to the following table for possible remedies. For minor problems, turning the water heater off and then turning back on may resolve the situation. If turning the water heater off and on and attempting the remedies suggested below do not resolve the problem, contact an authorized technician, licensed professional, or technical support at 1-800-761-0053.

Category	Problem	Possible Cause(s)	What to Do
Initial operation	Water heater does not ignite when water is running.	<ul style="list-style-type: none"> Are the gas and water pipes connected properly? 	<ul style="list-style-type: none"> Check for correct plumbing or crossed piping to the unit. Check the water inlet filter for debris.
	Unit attempts to ignite but fails	<ul style="list-style-type: none"> Is there air in the gas line? Is the gas supply pressure sufficient? 	<ul style="list-style-type: none"> Turn off the water heater and then turn it back on. Have your installing contractor check the gas supply pressure. Ensure the water heater is powered by 120 V-1 PH-60 Hz.
Temperature	Hot water is not produced when a faucet is opened.	<ul style="list-style-type: none"> Are the gas and water supply valves fully open? Is the water supply cut off to the household? Is gas being provided by the gas meter? Is there enough gas (for LP) in the tank? Is the water inlet filter clogged? Is the power button turned on? 	<ul style="list-style-type: none"> Fully open the gas and water supply valves. Check the water inlet filter for debris. Check the power status of the water heater.
	No water is available when a faucet is opened.	<ul style="list-style-type: none"> Is the water supply cut off? Is the water heater frozen? Are the pipes frozen? 	<ul style="list-style-type: none"> Open the cold water supply. Check if the water heater and/or the pipes are frozen.
	The hot water is not at the correct temperature.	<ul style="list-style-type: none"> Is the hot water faucet sufficiently open? 	<ul style="list-style-type: none"> Fully open the hot water faucet.
	Water takes a long time to become hot after opening the hot water faucet.	<ul style="list-style-type: none"> Have you allowed enough time for the cold water in the pipes to drain out? 	<ul style="list-style-type: none"> Even though the unit may be operating properly, the cold water contained in the piping will need to flow through the faucet before the hot water can reach the faucet. Wait for several minutes.
	The water is too hot.	<ul style="list-style-type: none"> Are the gas and cold water supply valves fully open? Is the water temperature setting appropriate? 	<ul style="list-style-type: none"> If the cold water supply temperature is too high, it is possible for the temperature to be higher than the temperature set on the front panel. Decrease the water temperature on the front panel. If only a small amount of hot water is required, it is possible for the temperature to be higher than the temperature set on the front panel. Decrease the water temperature on the front panel. If the cold water supply passes through a solar pre-heating system, it passes for the delivered water temperature to be higher than the temperature set on the front panel.
	The water is not hot enough.	<ul style="list-style-type: none"> Are the gas and cold water supply valves fully open? Is the water temperature setting correct? 	<ul style="list-style-type: none"> Fully open the gas and cold water supply valves. Check the water temperature setting.
	Fluctuation in hot water temperature.	<ul style="list-style-type: none"> Is the water inlet filter clogged? 	<ul style="list-style-type: none"> Clean the water inlet filter for debris.

Error Codes

If an error code appears on the digital display, refer to the following chart for the reason, and a possible remedy for the situation.

Error Code	Cause	Self-diagnosis/Action
A0	Abnormal operation: flow control valve	Contact technical support.
A1	Abnormal operation: by-pass valve	Contact technical support.
A2	Abnormal operation: fan	<ul style="list-style-type: none"> • Clean the intake air filter. • Check the fan connector. • Contact technical support.
A3	Abnormal operation: data communication	Contact technical support.
A4	Overheating of heat exchanger	<ul style="list-style-type: none"> • Turn off the system for at least 30 minutes, and then restart it. • Contact technical support.
A5	Overheating	<ul style="list-style-type: none"> • Turn off the system for at least 30 minutes, and then restart it. • Contact technical support.
A6	Ignition error	<ul style="list-style-type: none"> • Ensure that the main gas supply valve is open. • Contact technical support.
A7	Abnormal operation: gas valve relay	<ul style="list-style-type: none"> • Turn off the main gas valve. • Contact technical support.
A8	Abnormal operation: gas valve	<ul style="list-style-type: none"> • Turn off the main gas valve. • Contact technical support.
A9	Exhaust temperature overheating	Flush the heat exchanger. See page 10. Contact technical support.
AA	Abnormal operation: inlet water sensor	Contact technical support.
AB	Abnormal operation: heat exchanger temperature sensor	Contact technical support.
AC	Abnormal operation: hot water temperature sensor	Contact technical support.
AD	Clog of condensate trap or no water in condensate trap	<ul style="list-style-type: none"> • Fill the condensate trap. • Contact technical support.
AE	Blockage of flue Pipe	<ul style="list-style-type: none"> • Clean the vent terminal. • Contact technical support.
AF	Low Water Cut Off Switch error	<ul style="list-style-type: none"> • Check the cold water supply. • Contact technical support

Please contact original installer, licensed professional, or VST technical support at 1-800-761-0053.

LIMITED WARRANTY for VST Products

FOR WARRANTY SERVICE OR REPAIR:

Contact the installer or a VST dealer. You may be able to find the installer's name on the equipment or in your invoice. For further assistance, you may visit our website www.vestahws.com or call our customer service at 800-761-0053 or write to our address. VESTA, DS, Inc. 2711 Lyndon B Johnson Freeway Ste 320 Farmers Branch, TX 75234 VESTA, DS, Inc. (hereinafter "VST") warrants this product against failure due to defect in materials or workmanship when the product is installed and operated according to VST's written installation instructions, subject to the terms within this Limited Warranty document.

This Limited Warranty applies only to products that are installed correctly in the United States. Improper installation may void this Limited Warranty. In order for this warranty to apply, it is required that the subject water heaters utilized in heating applications that have been properly installed by qualified professionals based upon the manufacturer's installation instructions. Using the licensed professional who has attended a VST installation training class before installing this water heater is strongly recommended. Proof of purchase is required to obtain warranty service. You may provide proof of purchase with a dated sales receipt, or by registering within thirty (30) days of purchasing the product. This Limited Warranty coverage as set out in the table below extends to the original purchaser and subsequent owners, but only while the product remains at the site of the original installation. This Limited Warranty only extends to the first / original installation of the product and terminates if the product is moved or reinstalled at a new location. It is not transferable.

UNLESS OTHERWISE NOTED THESE WARRANTIES COMMENCE ON THE DATE OF PURCHASE. If at the time of a request for service the owner cannot provide a copy of the original sales receipt or the warranty registration, the warranty period for the water heater shall then be deemed to have commenced thirty (30) days after the date of manufacture of the water heater and NOT the date of installation of the water heater.

Item	Period of Coverage (from date of purchase)	
	Residential Applications	Commercial Applications
Heat Exchanger	15 years	8 years
All Other Parts and Components	5 years	3 years
Reasonable Labor	1 year	1 year

LIMITATIONS OF WARRANTIES: ALL IMPLIED WARRANTIES AND/OR CONDITIONS (INCLUDING IMPLIED WARRANTIES OR CONDITIONS OF MERCHANTABILITY AND FITNESS FOR A PARTICULAR USE OR PURPOSE) ARE LIMITED TO THE DURATION OF THIS LIMITED WARRANTY. SOME STATES OR PROVINCES DO NOT ALLOW LIMITATIONS ON HOW LONG AN IMPLIED WARRANTY OR

CONDITION LASTS, SO THE ABOVE MAY NOT APPLY TO YOU. THE EXPRESS WARRANTIES MADE IN THIS WARRANTY ARE EXCLUSIVE AND MAY NOT BE ALTERED, ENLARGED, OR CHANGED BY ANY DISTRIBUTOR, DEALER, OR OTHER PERSON, WHATSOEVER.

The following is Not covered.

- Service trips to your home to teach you how to use the product.
- Normal maintenance as outlined in the installation manual or Owner's Manual, including filter cleaning and/or replacement.
- Improper installation (such as but not limited to) • product being installed in a corrosive environment • condensate damage • improper venting • incorrect gas type • incorrect gas or water pressure • absence of a drain pan under the appliance
- Improper delivery or maintenance.
- Failure of the product if it is abused, misused, altered or used for other than the intended purpose.
- Use of this product where water is microbiologically unsafe or of unknown quality, without adequate disinfection before or after the system.
- Replacement of house fuses or resetting of circuit breakers.
- Damage to the product caused by accident, lightning fire, flood or acts of God.
- Incidental or consequential damage caused by possible defects with this appliance, its installation or repair.
- Product not accessible to provide required service in a safe manner. Attic installation must have flooring and accessible stairs.
- This Limited Warranty does not apply to any product whose serial number or manufacture date has been defaced.
- If product removed from original installation location.
- If product or other appliance must be moved for service access.
- Damages, malfunctions or failure caused by the use of repair service not approved by VST.
- Damages, malfunctions or failure caused by the use of unapproved parts or components.
- Damages, malfunctions or failure caused by subjecting the tank to pressure greater than those shown on the rating label.
- Damages, malfunctions or failure caused by operating the water heater with electrical voltage outside the voltage range listed on the rating label.
- Damages, malfunctions, or failure caused by operating the water heater with an empty or partially empty tank ("dry firing"), or failures caused by operating the water heater when it is not supplied with potable water.
- Failure of the heater due to the accumulation of solid materials and lime deposits.
- Water heater failure due to the water heater being operated in a corrosive or contaminated atmosphere.

- Any shipping charges, delivery expenses, or administrative fees incurred by the owner in repairing or replacing the water heater or part(s). This warranty does not extend to labor costs beyond the coverage specified in this warranty document. All such expenses are the owner's responsibility.
- ANY SPECIAL, INDIRECT OR CONSEQUENTIAL PROPERTY OR COMMERCIAL DAMAGE OF ANY NATURE WHATSOEVER.
- Some states or provinces do not allow the exclusion of incidental or consequential damages, so the above limitation may not apply to you. This Warranty gives you specific legal rights, and you may also have other rights which vary from state to state or province to province.
- If a follow up repair call involves the same problem which Installer had previously repaired within the preceding three (3) month period.
- If the Limited Warranty is void or not applicable for any reason.
- If Installer's request for payment for labor and services rendered is received by VST more than two (2) weeks after the repair or replacement service was completed.
- If it is determined by VST that the claim for payment of labor and services rendered was not for services directly necessary to replace or repair the defective Product such as for maintenance of the Product.
- If a component or product returned to VST is found to be free of defects in material or workmanship; damaged by improper installation, use or operation; or damaged during return shipping.

Warranty Claim & Return Procedures

To initiate a warranty claim, the homeowner or the end user may contact the original installer, distributor, or a VST. If the Installer is notified of the claim directly, Installer shall promptly inspect the Product and installation. If Installer determines in good faith that the warranty may apply, then Installer shall promptly call VST Tech Support at 1-800-761-0053 and provide details of the nature of the claim including the end-user's name, telephone number, address; model and serial numbers, and date of installation. VST reserves the right in its sole discretion to dispatch its own technician or other installer to complete the warranty repair.

No later than two (2) weeks following the completion of the repair, Installer shall transmit a fully completed Labor Claim Supplement form, provided by VST as follows: By e-mail to warranty@vestahws.com.

The replacement water heater will be warranted for the unexpired portion of the applicable warranty period of the original water heater. The number of replacement water heaters is limited to one (1) per original water heater purchased. Replacement parts will be warranted for 90 days.

This limited warranty is subject to all provisions, conditions, and limitations. VST reserves the right to change specifications or discontinue models without notice.

Labor Claim is denied

Installer's claim of payment for labor and services rendered may be denied entirely or reduced in the event Installer fails to strictly comply with the requirements set forth in this Agreement and for other applicable reasons including the following:

- If the Installer's claim for payment exceeds the fee or rate specified by VST. VST shall only be obligated to pay the rate or fee previously specified by VST and Installer shall not look to any other party, including the wholesaler or end-user, for such additional payments. The commencement of work by Installer shall constitute Installer's unequivocal and unconditional acceptance of the fee or rate designated by VST and Installer's acknowledgment and agreement to VST's designated fee or rate.
- If Installer fails to provide all required information including the end-user's name, address and telephone number, model and serial number, date of original installation; if such required information and/or documents are not submitted when requested.
- If the repair or replacement was not properly completed, if the end-user is dissatisfied with the repair, and/or a discrepancy is identified between the repair identified in the Claim Letter and the repair that was actually performed.

PRODUCT REGISTRATION

Thank you for purchasing VST product. Additional benefits may be offered on registered products. We will use the information provided on this registration to contact you when there is a safety alert or recall for this product. We do NOT sell, rent, or share our personal information. Please fill out online Product Registration or email it to info@vestahws.com

Purchase Date:

Model No:

Natural Gas:

Propane:

Serial No:

Owner Name:

Owner Address:

Owner Phone No:

Owner E-mail:

Installer Name:

Installer Business Name & Address:

Installer Phone No:

Installer E-mail:

Customer Survey

What made you to select our product?

- Advertising - Newspaper, magazine, brochure, preview
- Friends or Family
- Recommended by installing/service contractor
- Saw it in the store
- Online search
- Other:

Previously owned product

- Tank-type water heater
- Tankless water heater
- Conventional boiler
- Tankless boiler
- Online search

Age of previously owned product

- 1 - 5 yrs
- 6 - 10 yrs
- 11 - 15 yrs
- 16 - 20 yrs
- Online search

How many people living in your house?

How many bathrooms in you house?

Memo



Memo



Memo



VESTA. DS, Inc.

2711 LBJ Fwy Suite#320, Farmers branch, TX 75234

For Technical Support

1-800-761-0053

www.vestahws.com

Ver. 4.0